

Information Notice

SUBJECT: EQUIPMENT AND FURNISHINGS

Isolation between Cockpit and Passenger Compartment

For the attention of



AFFECTED HELICOPTERS	Model(s)	
	Civil	Military
EC120	B	–
AS350	B, BA, BB, B1, B2, B3, D	L1
AS550	–	A2, C2, C3, U2
AS355	E, F, F1, F2, N, NP	–
AS555	–	AF, AN, SN, UF, UN, (AP)
EC130	B4, T2	–
SA365 / AS365	C, C1, C2, C3, N, N1, N2, N3	F, Fs, Fi, K, K2
AS565	–	MA, MB, SA, SB, UB, MBe
SA366	G1	GA
EC155	B, B1	–
SA330	J	Ba, L, Jm, S1, Sm
SA341	G	B, C, D, E, F, H
SA342	J	L, L1, M, M1, Ma
ALOUETTE II	313B, 3130, 318B, 318C, 3180, 3180B, 3180C	–
ALOUETTE III	316B, 316C, 3160, 319B	–
LAMA	315B	–
EC225	LP	–
EC725	–	AP
AS332	C, C1, L, L1, L2	B, B1, F1, M, M1
AS532	–	A2, U2, AC, AL, SC, UE, UL
EC175	B	–
BO105	C (C23, CB, CB-4, CB-5), D (DB, DBS, DB-4, DBS-4, DBS-5), S (CS, CBS, CBS-4, CBS-5), LS A-3	CBS-5 KLH, E-4
MBB-BK117	A-1, A-3, A-4, B-1, B-2, C-1, C-2, C-2e, D-2, D-2m	D-2m
EC135	T1, T2, T2+, T3, P1, P2, P2+, P3, EC635 T1, EC635 T2+, EC635 T3, EC635 P2+, EC635 P3, T3H, P3H, EC635 T3H, EC635 P3H	–

Due to the Corona-Virus crisis many operators have been requested to provide support for special operations that require additional equipment for isolating the cabin and cockpit. Airbus Helicopters is actively involved supporting operators in these role changes and is also aware that many operators are working independently to facilitate and protect their crews with these new demands.

This Information Notice (IN) is prepared to assist operators with Cabin Cockpit Isolation, provide details on Ventilation, Heating and Air Conditioning System and to share reference information regarding isolation transport devices currently in use by some operators.

1. Cabin Cockpit Isolation

Cabin cockpit isolation is intended to provide a barrier between the infected or possibly infected patients and the flight crews. While in a helicopter a 100 % barrier is not possible, any additional barrier will increase the level of protection:

Many aircraft are already configured with NVG curtains or equivalent and these are considered as a level of protection.

Airbus Helicopters is aware that it would not be possible to design, approve and supply Service Bulletin (SB) installations and kits in the time frame to meet the current crisis demand. Therefore, to be most reactive in this situation, Airbus Helicopter is working to develop and provide, Minor Minor Change Approval Sheets for operators that are based on locally available material. The Minor Minor Change Approval Sheets contain details of locally obtainable materials and guidelines for the installation. In Appendix 1 to this IN are the STCs for the EC135 and MBB-BK117 C-2, D-2. The IN will be revised as further Minor Minor Change Approval Sheets become available.

Airbus Helicopters is currently investigating the possibility of creating Minor Minor Change Approval Sheets to include the following Aircraft types: H155, H175, AS332 and H225. Additional solutions are also being investigated for the light range.

Operators are able to use these Minor Minor Change Approval Sheets to facilitate the most time efficient installations.

Airbus Helicopters is also aware that many operators are currently developing their own installations and in combination with the possibility that the Minor Minor Change Approval Sheets cannot be applied, Airbus Helicopters is offering support, where required, in the form of NTO/Technical Statement to support operators in obtaining local approval for their individual installations.

To request NTO/Technical Statement assistance kindly contact your local Airbus Helicopters support providing details of the installation, the material, weight, location and method of installation plus any other installation relevant details. Airbus Helicopters will provide assistance where possible however, it is not guaranteed all installations will be suitable for NTO/Technical Statement support.

An easily removable, permanent medical separation wall is certified and available for the MBB-BK117-D2 (not currently certified for the MBB-BK117-C2) refer to details of installation below. Further information on this installation can be obtained by contacting MECAER Aviation Group directly.

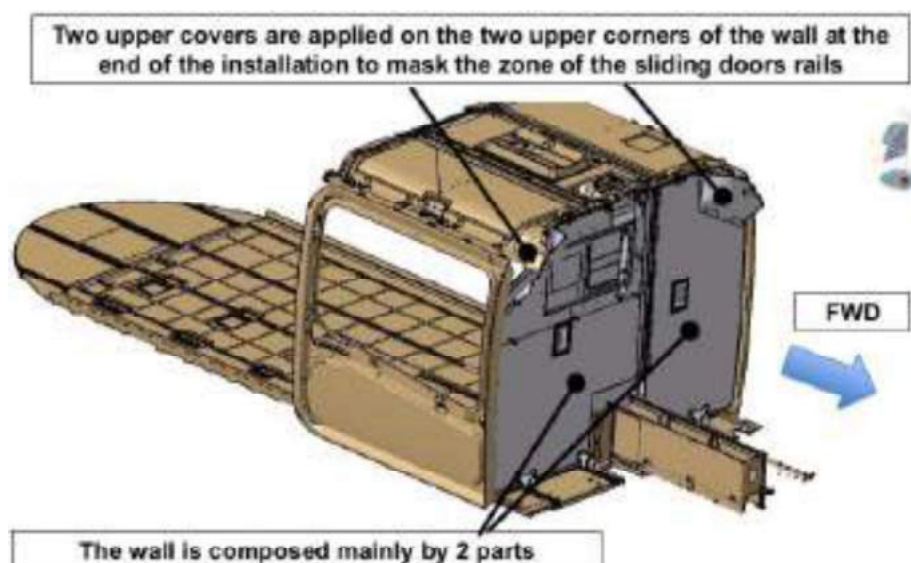

2. Ventilation, Heating and Air Conditioning System

Airbus Helicopters have not imposed any operational restrictions related to the ventilation, heating and air-conditioning systems, however many questions have been received on this subject. Airbus Helicopters reminds operators that any changes made to the subject systems could have possible effects on the certification basis of the aircraft. These changes could affect for example, the vital functions of De misting

Therefore Airbus Helicopter have assembled a guide (see Appendix 2) detailing the Air-Distribution system, and how to

- have only fresh (i.e. external) air supply and
- to minimize the circulation of air from Cabin to Cockpit

3. Reference Information Regarding Isolation Transport Devices Used By Operators

Airbus Helicopters are aware that operators are faced with varying requests related to transporting patients using Isolation Transport Devices, details of these are available on the various forums.

It is not practical to list these various installations in this IN however Airbus Helicopters remains available to assist operators with NTO/Technical Statement to accommodate the expanding needs of the operators. Details for requesting NTO/Technical Statement support are listed in Paragraph 1 of this IN.

4. Disinfection reminder

Airbus Helicopters reminds operators that all curtains and equipment, regardless of installation or material, should be cleaned and disinfected to remove and kill pathogens to lower the risk of spreading infection. Further details of disinfection of Helicopters can be found in the Airbus Helicopters IN 3476-I-12.

Appendix:

Appendix 1: Minor Minor Change Approval Sheets:

- EC135
- MBB-BK117 C-2, D-2

Appendix 2: Air-Conditioning: Air-Distribution Principle Sum-Up

This Minor Minor Change Approval is approved by AHD DO EASA.21J.383, acting on behalf of privilege 21A.263(c)2 and certifies that the change in the Type Certificate for the product listed below with the limitations and conditions specified meets the applicable Type Certification Basis, OSD Certification Basis and environmental protection requirements when operated within the conditions and limitations specified below. No feature or characteristic has been identified that may make the product unsafe for the uses for which certification is requested.

Aircraft Type	EC135	Owner / Operator	all
Registration No	all	Serial No	all

Title
Cabin Separation Guide

Brief description of change (content, function, etc.)

The current certification project aims to be a quick and pragmatic solution for our customers to install a cabin temporary separation between crew and passengers. It does not contain a material kit, but only give a guideline how to install a separation and what to take care of with regards to the material selection.

The intended function of the separation is to reduce the likelihood of droplet infection between crew and passengers inside the cabin. The installation is meant to be a temporary solution to quickly respond to the needs of the current health crisis.

Installation overview

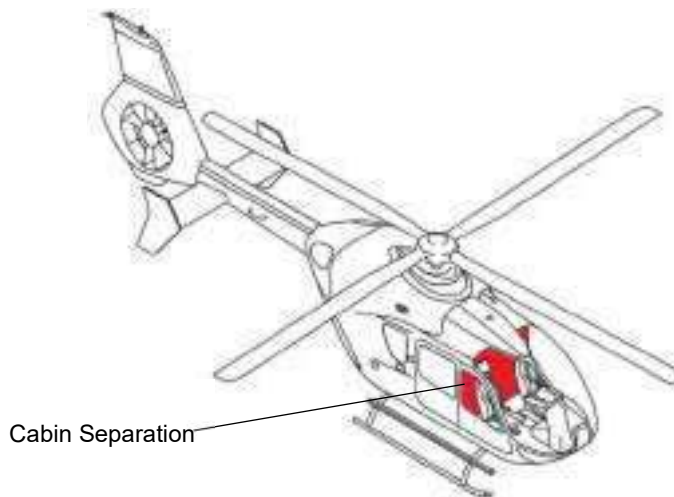

TCDS ref. / Certification Basis / list of affected specification requirements

TCDS: EASA.R.009, Issue 16 (05.07.2019)

Certification Basis: CS 27 Amd 2

Applicable Requirements: CS 27.1, CS 27.601 Design, CS 27.771 Pilot Compartment,

Compliance statement

The modification is carried out with well-known design principles and procedures, where experience shows the safety of design. No further investigations are necessary to show compliance to the above mentioned requirements

Master document list

- [1] SK-MIC-220-CR-B-2058 A Change Request
- [2] SK-MIC-220-CDC-B-2059 A Classification of Design Change

Other data from TC / STC holder (e.g. reports, NTO, etc.)

N/A

Approvals	Engineering / Engineering Documents	Configuration	Compliance with Airworthiness Codes <small>CVE Mechanics</small>	Compliance with Airworthiness Codes <small>CVE Avionics</small>	Completion of MMCA acc. to DOA procedures <small>AWO</small>	Minor Minor Change Approval <small>HDO</small>
Name	Kniemeyer	Kniemeyer	Angermeyer	N/A	Steinbrecher	Plessing
Date						
Signature						

The technical content of this Minor Minor Change is approved under the Authority of DOA ref. EASA.21J.383.

The transmission and reproduction of this document and the utilization and communication of its contents are prohibited unless expressly admitted. The non-observance of this clause will lead to liability to respond in damages. All rights reserved as regards the issue of patents or registration of design patents.

Index

1	Revision History	2
2	Affected Publication.....	2
3	Manpower	2
4	Interchangeability	2
5	Material Information.....	3
6	Weight, Balance, Power	3
7	Reidentified Parts	3
8	Accomplishment Instructions	3
9	Operational Procedures.....	7
10	Instructions for Continued Airworthiness	7
11	Change Documentation	7

1 Revision History

Date	Revision Index	Comment
02.04.2020	A	New document

2 Affected Publication

N/A

3 Manpower

1 or 2 technicians

4 Interchangeability

Not affected

5 Material Information

No material kit is specified. The proposed material in the list below should be purchased off-the-shelf by the customer due to public crisis times.

QTY	PART NUMBER	DEFINITION	DISPOSITION
4	NOT SPECIFIED	ANGULAR BRACKET ALUMINUM OR STAINLESS STEEL	BFE
4	NOT SPECIFIED	WIRE ATTACHMENT PARTS; STAINLESS STEEL	BFE
AR	NOT SPECIFIED	METAL WIRE ROPE (d=2 – 3mm); STAINLESS STEEL	BFE
AR	NOT SPECIFIED	FOIL AT LEAST ACC TO EN 13501-1; APPROX 50 g/m ² ; TRANSPARENT	BFE
AR	NOT SPECIFIED	HOOK TAPE, SELF ADHESIVE	BFE
AR	NOT SPECIFIED	LOOP TAPE, SELF ADHESIVE	BFE
AR	NOT SPECIFIED	EDGE PROTECTION e.g./ similar to TPEN7/ MBBN3406-7	BFE
4	EN3308-050018F OR LN9038-05018	SCREW, HEX HEAD	BFE

6 Weight, Balance, Power

negligible

7 Reidentified Parts

N/A

8 Accomplishment Instructions

8.1 General

(1) Comply with the Aircraft MTC

8.2 Installation procedure

Preparation of angular Bracket:

- (1) Buy or build four angular brackets that match the dimensions shown in Figure 1 and that can be attached to the door hook attachment screws. It can be made of sheet metal or aluminum profile with a thickness of at least 1,6mm and max 2,0mm
- (2) When building it of sheetmetal make sure to respect the minimum bending radius with regards to the kind of aluminum alloy, thickness, hardening condition as it is given by the respective standard.

Note in most cases a bending radius of 5mm is good for a metal sheet of 1,6mm thickness.

Note material recommendation is EN-AW 2024 T351 or similar/ higher valued

Note In case no such aluminum is available use stainless steel (thickness magnitude: 1,2 – 1,6mm). In this case don't do the surface protection as described in step (4).

Note the bending angle can be adapted to avoid the steal rope touching the cabin interior

Note the diameter of the upper hole has to be adapted to the attachment provisions or the wire rope. Maximum Diameter is 8mm.

(3) Deburr and smoothen all edges

(4) Do the surface protection in accordance (or equivalent) to LN9368-2000, LN9368-5000 and LN9368-5100 – black

(5) Apply edge protection to avoid crew injury when entering leaving the cabin

Note Based on the inspections as described in chapter 10, the aluminum angular bracket can be used without surface treatment when exchanged after 6 months latest.

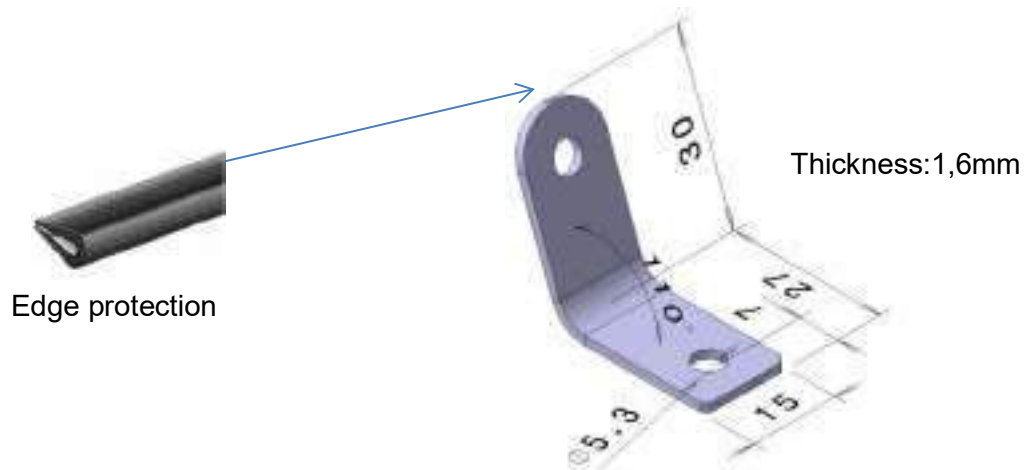

Figure 1: Example of Aluminum Angular Bracket

Installation of side facing wires

(6) Mark the position of the door hooks

(7) Carefully remove the backward facing screw and washer of pilot and co-pilot upper and lower door hook

(8) Attach the angular bracket to the door hook using screw EN3308-050018F or LN9038-05018 (shown in Figure 2 on the pilot side) and previously removed washer

Note in urgent cases and if no such screws available, re-use the previously removed screws without using the washer. Replace the screw by the one described within one month.

- (9) Assure that the door hooks are in same position as before removing the screws.
- (10) Cut the wire rope to a proper length to fit between the lower- and the upper angular bracket for pilot- and co-pilot side, taking into account the wire attachment parts. Examples for attachment parts are shown in Figure 3
- (11) Attach the wire to the lugs in the angular brackets using the wire attachment parts. Use a thimble as required

CAUTION

AVOID HIGH TENSION ON THE WIRE ROPE – IT SHOULD BE JUST NOT HANGING LOOSE.

CAUTION

MAKE SURE THE WIRE ROPE RUNS TOTALLY FREE AND DOES NOT TOUCH ANY OBSTACLE WITHIN THE CABIN/ INTERIOR TO AVOID DAMAGE. THIS CAN BE INFLUENCED E.G. BY THE BENDING ANGLE OF THE ANGULAR BRACKET.

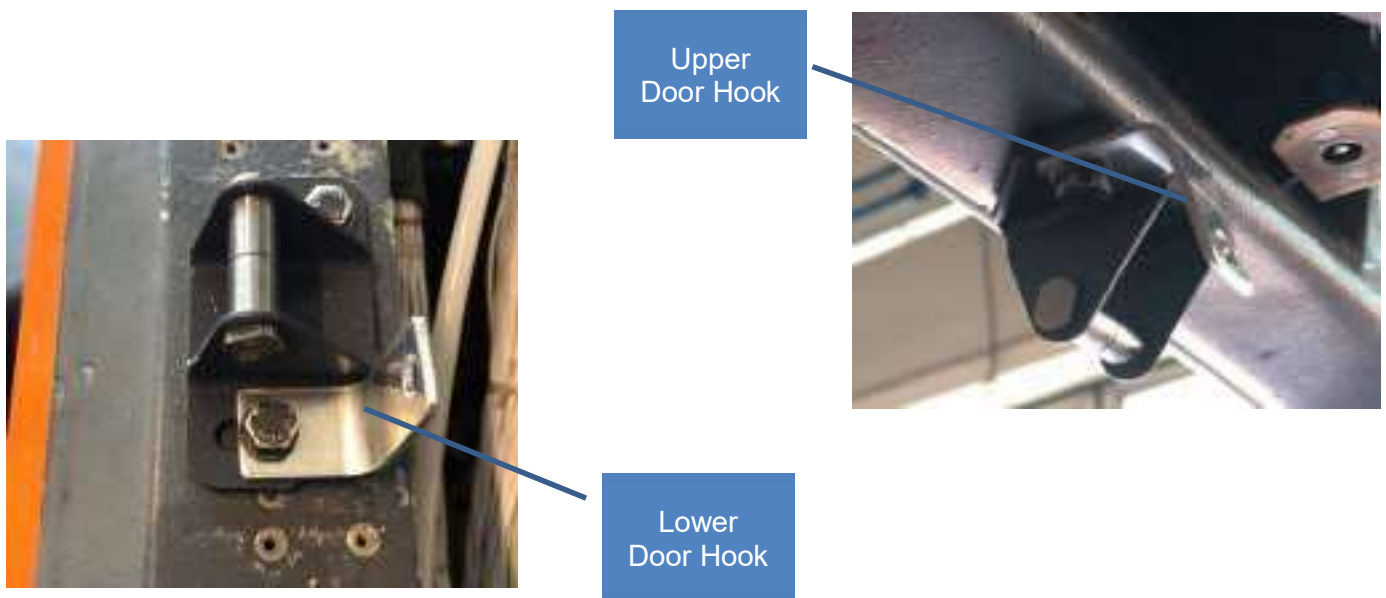

Figure 2: Door Hooks (co-pilot side)



Figure 3: Example of Attachment Parts for wire ropes available off-the-shelf (metal crimp/ thimble)

Installation of Welcro

(12) Install self-adhesive hook tape on the floor and at the ceiling approx. at STA3000 as well as on the center post (as required)

Note When purchasing self-adhesive welcro make sure it claims to resist the temperatures you expect inside the cabin also during parking – otherwise it might fall off, most likely resulting in a loss of protection against the droplet infection

CAUTION

MAKE SURE NOT TO COVER ANY LABELS OR INSTALLATIONS AT THE CENTER POST



Figure 4: Example for welcro

Preparation and installation of the foil (refer to Figure 5)

(13) Cut the foil in shape that matches the cabin – make sure to keep it a bit longer at the LH and RH side in order to be able to loop it around the wire rope

CAUTION

WHEN PLANNING THE CUTTING OF THE FOIL MAKE SURE IT CAN BE INSTALLED IN A WAY THAT THE CREW STILL HAS ACCESS TO THE FIRE EXTINGUISHER. IF NECESSARY SEPARATE THE FOIL AND ATTACH BOTH SIDES TO THE CENTER POST USING WELCRO

(14) Attach loop tape to the upper and lower edge of the foil as well as to the side facing edges

(15) Attach hook tape in parallel to the loop tape on the side facing edges, with a distance just enough for being able to loop the foil around the wire and fix it together

(16) If required attach loop tape to the foil in the area of the center post hook tape

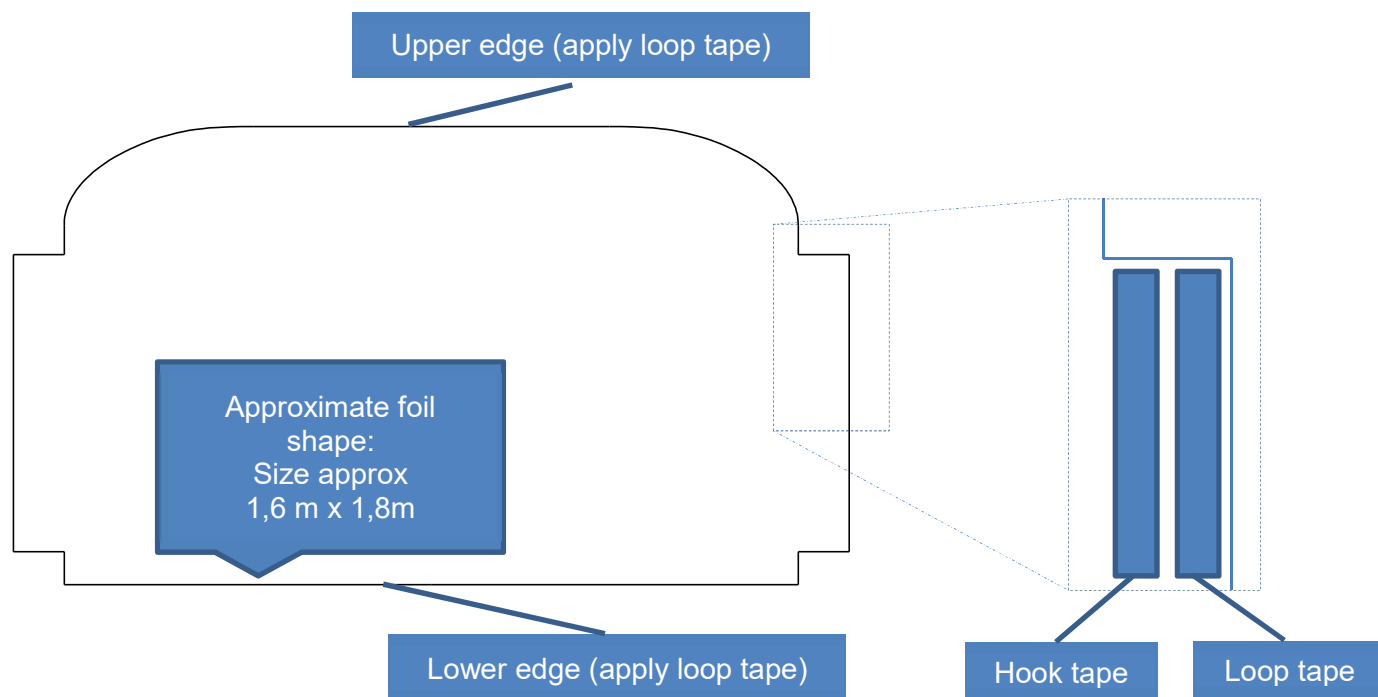

Figure 5: schematic for the foil preparation

9 Operational Procedures

N/A

10 Instructions for Continued Airworthiness

Airworthiness Limitations

N/A

Master Servicing Recommendations

- (1) Check the integrity of the installation visually before each flight.

11 Change Documentation

N/A

This Minor Minor Change Approval is approved by AHD DO EASA.21J.383, acting on behalf of privilege 21A.263(c)2 and certifies that the change in the Type Certificate for the product listed below with the limitations and conditions specified meets the applicable Type Certification Basis, OSD Certification Basis and environmental protection requirements when operated within the conditions and limitations specified below. No feature or characteristic has been identified that may make the product unsafe for the uses for which certification is requested.

Aircraft Type	BK117 C-2/ D-2	Owner / Operator	all
Registration No	all	Serial No	9004 and subsequent / 20003 and subsequent

Title
Cabin Separation Guide

Brief description of change (content, function, etc.)

The current certification project aims to be a quick and pragmatic solution for our customers to install a cabin temporary separation between crew and passengers. It does not contain a material kit, but only give a guideline how to install a separation and what to take care of with regards to the material selection.

The intended function of the separation is to reduce the likelihood of droplet infection between crew and passengers inside the cabin. The installation is meant to be a temporary solution to quickly respond to the needs of the current health crisis.

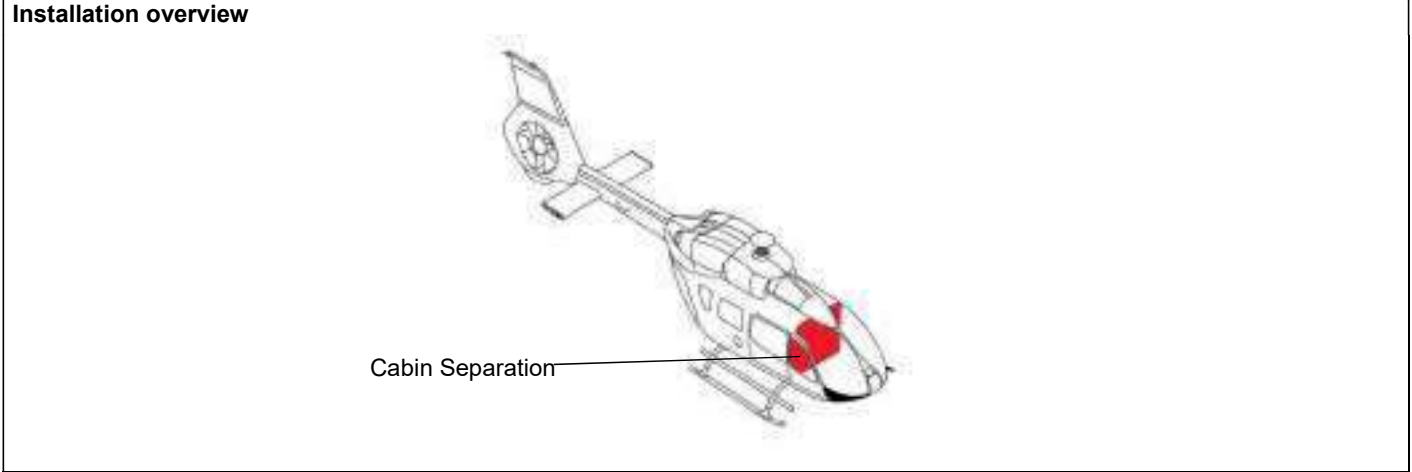

TCDS ref. / Certification Basis / list of affected specification requirements

TCDS: EASA.R.010, Issue 16 (06.03.2019)
 Certification Basis: CS-29, Amdt. 2 / FAR 29 Amdts. 1-40
 Applicable Requirements: CS 29.1, FAR 29.601 Design, CS 29.771 Pilot Compartment,

Compliance statement

The modification is carried out with well-known design principles and procedures, where experience shows the safety of design. No further investigations are necessary to show compliance to the above mentioned requirements

- Master document list**
- [1] SK-MIC-221-CR-R-2061 A Change Request
 - [2] SK-MIC-221-CDC-R-2062 A Classification of Design Change

Other data from TC / STC holder (e.g. reports, NTO, etc.)

N/A

Approvals	Engineering / Engineering Documents	Configuration	Compliance with Airworthiness Codes <small>CVE Mechanics</small>	Compliance with Airworthiness Codes <small>CVE Avionics</small>	Completion of MMCA acc. to DOA procedures <small>AWO</small>	Minor Minor Change Approval <small>HDO</small>
Name	Kniemeyer	Kniemeyer	Angermeyer	N/A	Steinbrecher	Plessing
Date						
Signature						

The technical content of this Minor Minor Change is approved under the Authority of DOA ref. EASA.21J.383.
 The transmission and reproduction of this document and the utilization and communication of its contents are prohibited unless expressly admitted. The non-observance of this clause will lead to liability to respond in damages. All rights reserved as regards the issue of patents or registration of design patents.

Index

1	Revision History	2
2	Affected Publication.....	2
3	Manpower	2
4	Interchangeability	2
5	Material Information.....	3
6	Weight, Balance, Power	3
7	Reidentified Parts	3
8	Accomplishment Instructions	3
9	Operational Procedures.....	7
10	Instructions for Continued Airworthiness	7
11	Change Documentation	7

1 Revision History

Date	Revision Index	Comment
03.04.2020	A	New document

2 Affected Publication

N/A

3 Manpower

1 or 2 technicians

4 Interchangeability

Not affected

5 Material Information

No material kit is specified. The proposed material in the list below should be purchased off-the-shelf by the customer due to public crisis times.

QTY	PART NUMBER	DEFINITION	DISPOSITION
4	NOT SPECIFIED	ANGULAR BRACKET ALUMINUM OR STAINLESS STEEL	BFE
4	NOT SPECIFIED	WIRE ATTACHMENT PARTS; STAINLESS STEEL	BFE
AR	NOT SPECIFIED	METAL WIRE ROPE (d=2 – 3mm); STAINLESS STEEL	BFE
AR	NOT SPECIFIED	FOIL AT LEAST ACC TO EN 13501-1; APPROX 50 g/m ² ; TRANSPARENT	BFE
AR	NOT SPECIFIED	HOOK TAPE, SELF ADHESIVE	BFE
AR	NOT SPECIFIED	LOOP TAPE, SELF ADHESIVE	BFE
AR	NOT SPECIFIED	EDGE PROTECTION e.g./ similar to TPEN7/ MBBN3406-7	BFE
4	EN3308-050018F OR LN9038-05018	SCREW, HEX HEAD	BFE

6 Weight, Balance, Power

negligible

7 Reidentified Parts

N/A

8 Accomplishment Instructions

8.1 General

(1) Comply with the Aircraft MTC

8.2 Installation procedure

Preparation of angular Bracket:

- (1) Buy or build four angular brackets that match the dimensions shown in Figure 1 and that can be attached to the door hook attachment screws. It can be made of sheet metal or aluminum profile with a thickness of at least 1,6mm and max 2,0mm
- (2) When building it of sheetmetal make sure to respect the minimum bending radius with regards to the kind of aluminum alloy, thickness, hardening condition as it is given by the respective standard.

Note in most cases a bending radius of 5mm is good for a metal sheet of 1,6mm thickness.

Note material recommendation is EN-AW 2024 T351 or similar/ higher valued

Note In case no such aluminum is available use stainless steel (thickness magnitude: 1,2 – 1,6mm). In this case don't do the surface protection as described in step (4).

Note the bending angle can be adapted to avoid the steal rope touching the cabin interior

Note the diameter of the upper hole has to be adapted to the attachment provisions or the wire rope. Maximum Diameter is 8mm.

(3) Deburr and smoothen all edges

(4) Do the surface protection in accordance (or equivalent) to LN9368-2000, LN9368-5000 and LN9368-5100 – black

(5) Apply edge protection to avoid crew injury when entering leaving the cabin

Note Based on the inspections as described in chapter 10, the aluminum angular bracket can be used without surface treatment when exchanged after 6 months latest.

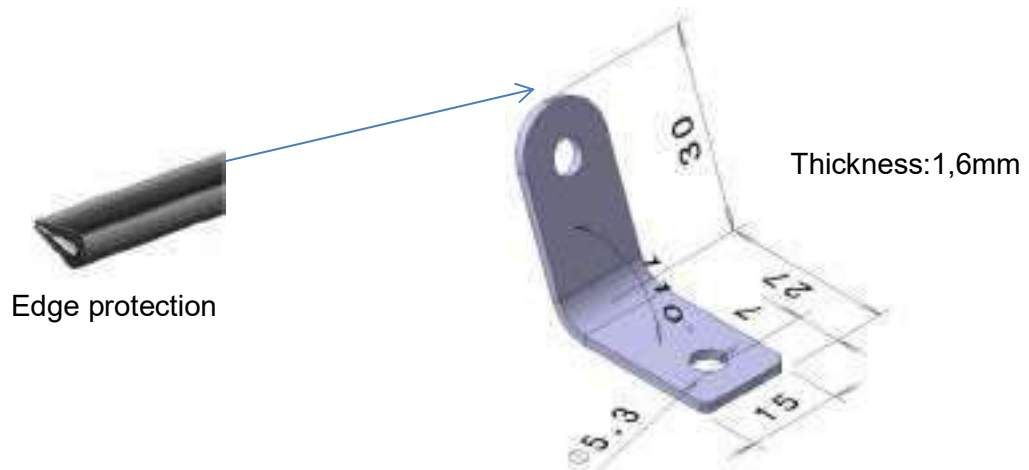

Figure 1: Example of Aluminum Angular Bracket

Installation of side facing wires

(6) Mark the position of the door hooks

(7) Carefully remove the backward facing screw and washer of pilot and co-pilot upper and lower door hook

(8) Attach the angular bracket to the door hook using screw EN3308-050018F or LN9038-05018 (shown in Figure 2 on the pilot side) and previously removed washer

Note in urgent cases and if no such screws available, re-use the previously removed screws without using the washer. Replace the screw by the one described within one month.

- (9) Assure that the door hooks are in same position as before removing the screws.
- (10) Cut the wire rope to a proper length to fit between the lower- and the upper angular bracket for pilot- and co-pilot side, taking into account the wire attachment parts. Examples for attachment parts are shown in Figure 3
- (11) Attach the wire to the lugs in the angular brackets using the wire attachment parts. Use a thimble as required

CAUTION

AVOID HIGH TENSION ON THE WIRE ROPE – IT SHOULD BE JUST NOT HANGING LOOSE.

CAUTION

MAKE SURE THE WIRE ROPE RUNS TOTALLY FREE AND DOES NOT TOUCH ANY OBSTACLE WITHIN THE CABIN/ INTERIOR TO AVOID DAMAGE. THIS CAN BE INFLUENCED E.G. BY THE BENDING ANGLE OF THE ANGULAR BRACKET.

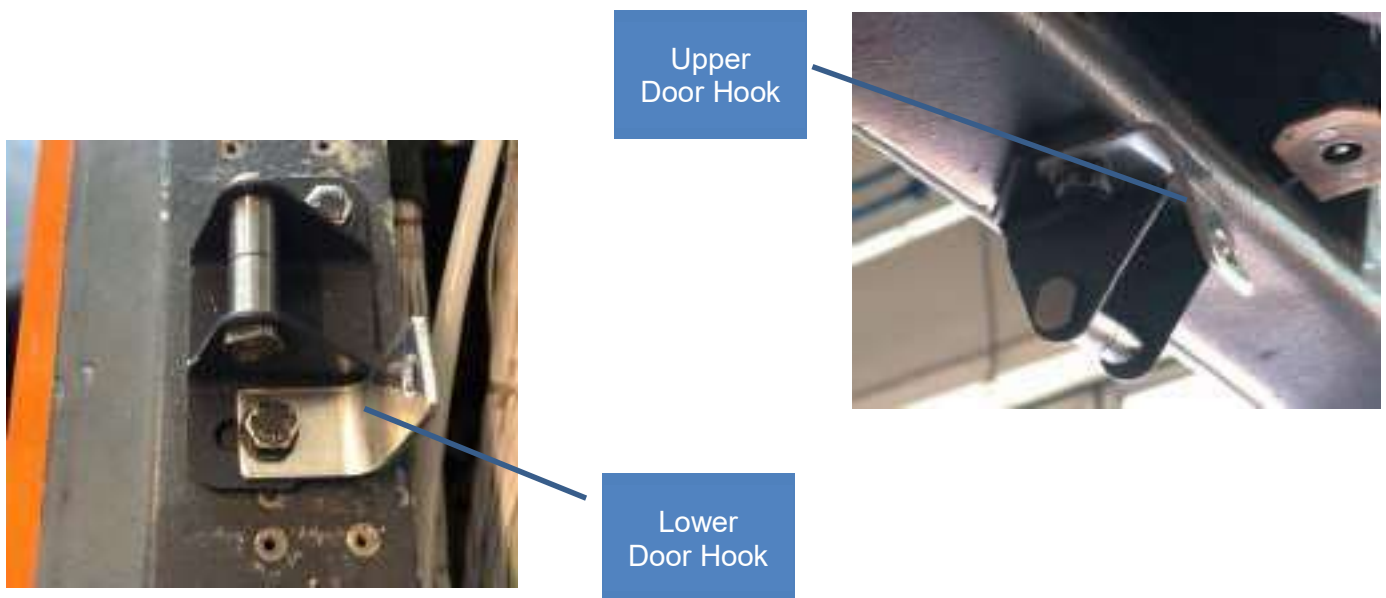

Figure 2: Door Hooks (co-pilot side; photos taken on EC135, but almost the same BK117)



Figure 3: Example of Attachment Parts for wire ropes available off-the-shelf (metal crimp/ thimble)

Installation of Welcro

(12) Install self-adhesive hook tape on the floor and at the ceiling approx. at STA3000.

Note When purchasing self-adhesive welcro make sure it claims to resist the temperatures you expect inside the cabin also during parking – otherwise it might fall off, most likely resulting in a loss of protection against the droplet infection



Figure 4: Example for welcro

Preparation and installation of the foil (refer to Figure 5)

(13) Cut the foil in shape that matches the cabin – make sure to keep it a bit longer at the LH and RH side in order to be able to loop it around the wire rope

CAUTION

WHEN PLANNING THE CUTTING OF THE FOIL MAKE SURE IT CAN BE INSTALLED IN A WAY THAT THE CREW STILL HAS ACCESS TO ANY CONTROL AND DEVICE INTENDED TO BE USED BY THEM

(14) Attach loop tape to the upper and lower edge of the foil as well as to the side facing edges

(15) Attach hook tape in parallel to the loop tape on the side facing edges, with a distance just enough for being able to loop the foil around the wire and fix it together

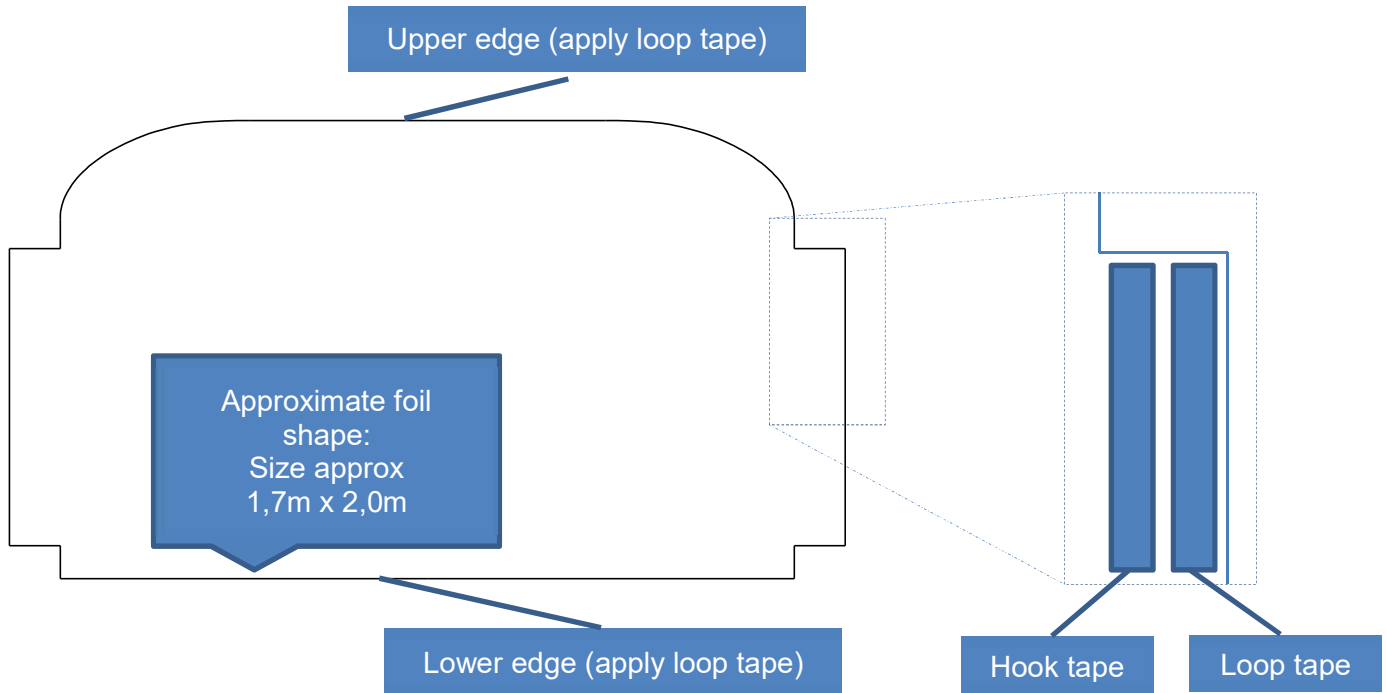

Figure 5: schematic for the foil preparation

9 Operational Procedures

N/A

10 Instructions for Continued Airworthiness

Airworthiness Limitations

N/A

Master Servicing Recommendations

(1) Check the integrity of the installation visually before each flight.

11 Change Documentation

N/A